

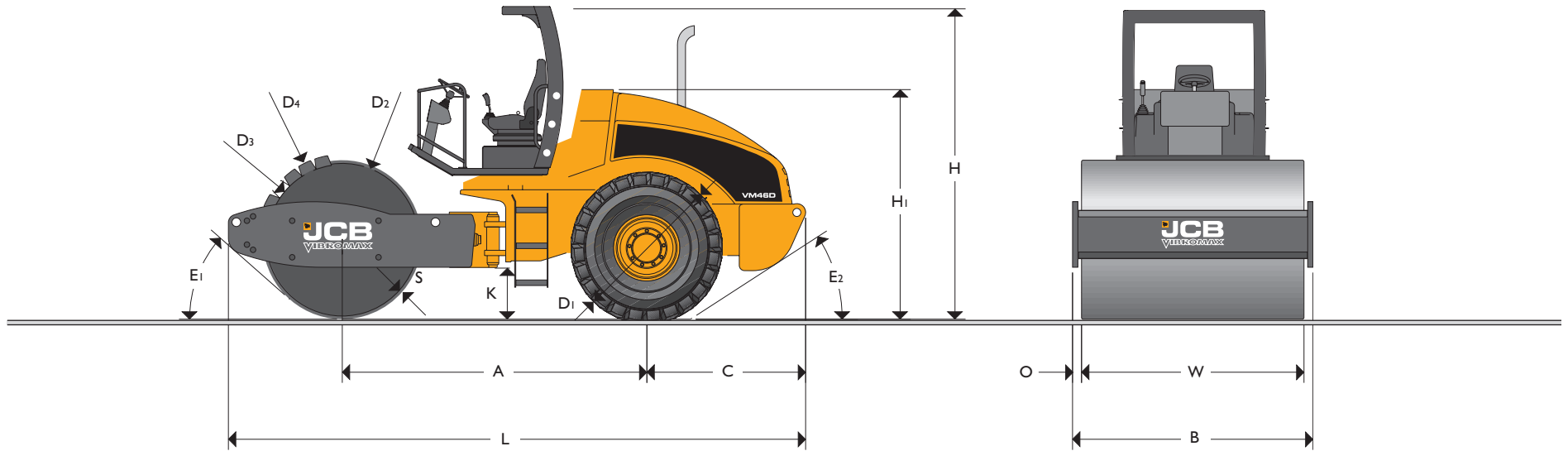

DRUM WIDTH: 55.1 in (1,400 mm) MAX OPERATING WEIGHT: 10,141 lb (4,600 kg) / 10,803 lb (4,900 kg) MAX HORSEPOWER: 60 hp



STATIC DIMENSIONS

Dimensions in inches (mm)		
A	Wheelbase	86.6 (2200)
B	Overall Width	59.8 (1520)
C	Axle to Rear Face	53.1 (1350)
D1	Wheel Diameter	46.3 (1176)
D2	Drum Diameter (smooth drum)	39.4 (1000)
D3	Inner Diameter Padfoot Drum	35.8 (910)
D4	Outer Diameter Padfoot Drum	42.1 (1070)
H	Total Travel Clearance	103.9 (2640)
H1	Height to Top of Seat	75.4 (1915)
K	Ground Clearance	13.2 (335)
L	Total Travel Length	172.2 (4375)
O	Overhang	2.4 (60)
S	Drum Thickness	0.8 (20)
W	Drum Width	55.1 (1400)
E1	Front Departure Angle	37°
E2	Rear Departure Angle	25°

OPERATING DATA

		VM46D	VM46PD
Operating Weight Max	lb (kg)	10,141 (4600)	10,803 (4900)
Operating Axle Load Front / Rear	lb (kg)	4850 (2200) / 5291 (2400)	5512 (2500) / 5291 (2400)
Operating Linear Load Front	lb/in (kg/cm)	88 (15.7)	
Exciter Frequency	vpm (Hz)	1920 (32)	1920 (32)
Nominal Amplitude	in (mm)	0.071 (1.8)	0.059 (1.5)
Centrifugal Force per Drum	lbf (kN)	22,841 (101.6)	22,841 (101.6)
Centrifugal Force / Drum Width	lbf/in (N/cm)	414 (726)	414 (726)
Compaction Depth up to	in (cm)	26 (65)	28 (70)
Working Speed (forward/reverse) Max	mph (km/h)	3.6 (5.8)	3.6 (5.8)
Travel Speed (forward/reverse) Max	mph (km/h)	7.9 (12.7)	7.9 (12.7)
Steering Lock Angle	degrees	±32	±32
Vertical Oscillation	degrees	±12	±12
Inner Turning Radius	in (m)	122 (3.1)	122 (3.1)
Tires		12.00 R20 XZL	12.4 - 24 Dyna Torque
Number of Padfeet			77
Height of Padfoot	in (mm)		3.1 (80)
Gradeability up to	degrees (%)	30 (58)	30 (58)



ENGINE

Four-cylinder, water-cooled, four-stroke, diesel engine.

Make		Cummins
Model		B 3.3
Engine Displacement	in ³ (cm ³)	199 (3260)
Performance – DIN 6271	hp (kW)	60 (45)
Operating Speed	rpm (min ⁻¹)	2200 (2200)
Starting Device		Electric motor
Air Cleaner		Dry Cartridge Plus Safety Cartridge
Fuel Filter		Cartridge
Fuel Consumption	gal (l/h)	1.8 (6.7)

PROPULSION

Infinitely variable hydrostatic direct drive by variable displacement motor on rear axle and drum, Multidisc self-locking differential (NoSPIN).

EXCITER DRIVE

Electrically controlled hydrostatic direct drive on drum.

EXCITER

Single-shaft circular exciter.

STEERING SYSTEM

Servo assisted center articulation with vertical oscillation.

SERVICE CAPACITIES

Fuel	gal (l)	47.6 (180)
Engine Oil (engine)	gal (l)	2.1 (8)
Gear Oil (exciter)	gal (l)	0.7 (2.5)
Hydraulic Oil	gal (l)	15.9 (60)
Coolant	gal (l)	3.7 (14)

BRAKING SYSTEM

Service Brake:	Hydrostatic propulsion system.
Parking Brake:	Hydraulically released multi-disk brake on rear axle and drum drive.
Emergency Brake:	Electrically controlled.

ELECTRICAL SYSTEM

Voltage	V	12
Battery Capacity	Ah	143
Alternator	A	Max 60

INDICATORS AND SWITCHES

Hour meter, fuel, engine temperature, engine oil pressure, battery charging current, hydraulic oil and air filter condition, parking brake, neutral position control lever, speed range selection, frequency. Optional lighting, turn signal, hazard-warning lights.



A GLOBAL COMMITMENT TO QUALITY

JCB's total commitment to its products and customers has helped it grow from a one-man business into one of the world's largest manufacturers of backhoe loaders, crawler excavators, wheeled excavators, telescopic handlers, wheeled loaders, dump trucks, rough terrain fork lifts, industrial fork lifts, mini/midi excavators, skid steer loaders and tractors.

By making constant and massive investments in the latest production technology, the JCB factories have become some of the most advanced in the world.

By leading the field in innovative research and design, extensive testing and stringent quality control, JCB machines have become renowned all over the world for performance, value and reliability.

And with an extensive dealer sales and service network in over 150 countries, we aim to deliver the best customer support in the industry.

Through setting the standards by which others are judged, JCB has become one of the world's most impressive success stories.



JCB Headquarters Savannah, 2000 Bamford Blvd, Savannah, GA 31322 Tel: (912) 447-2000 Fax: (912) 447-2299 www.jcb.com

JCB reserves the right to change design, materials and/or specifications without notice. Specifications are applicable to units sold in the United States and Canada. The JCB logo is a registered trademark of J C Bamford Excavators Ltd.