

MAX PAYLOAD: 4,400 lb (1,996 kg) MAX LIFT HEIGHT: 16 ft 5 in (5.0 m) MAX POWER: 77 hp (57.5 kW)

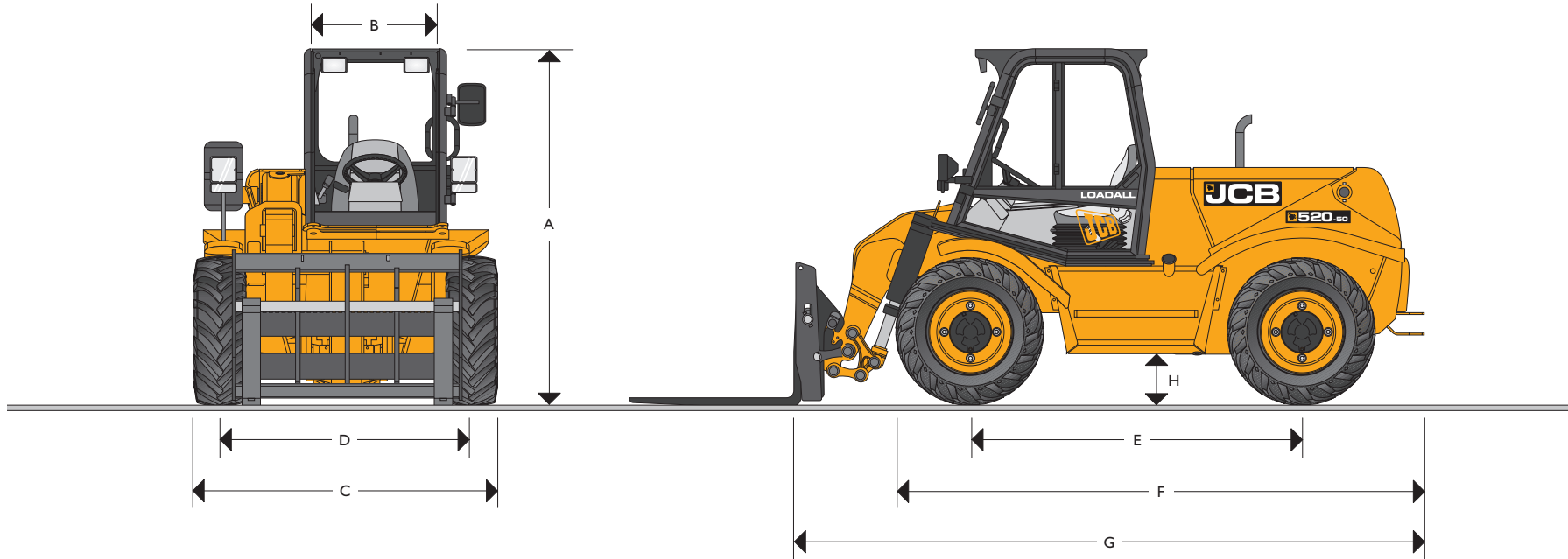

STATIC DIMENSIONS

Machine Model	520-50 ft-in (m)
A Overall Height (standard cab)	6-11 (2.12)
A Overall Height (low cab)	6-6 (1.99)
B Inside Width of Cab	2-7 (0.80)
C Width Over Tires (minimum)	6-0 (1.84)
D Front Track	5-0 (1.53)
E Wheelbase	6-7 (2.00)

Machine Model	520-50 ft-in (m)
F Overall Length to Front of Tires	10-1 (3.08)
G Overall Length to Front of Carriage	11-9 (3.59)
H Ground Clearance	1-0 (0.30)
Outer Turn Radius Over Tires	10-2 (3.10)
Weight	lb (kg) 10,736 (4870)
Tires	10 x 18 10 pr

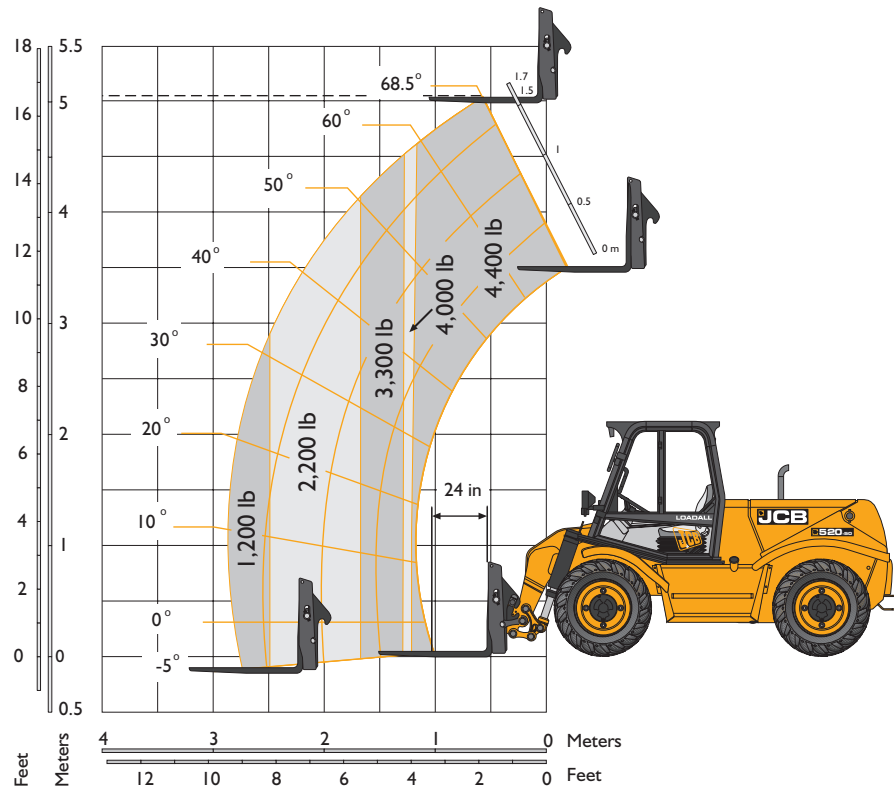

LIFT PERFORMANCE

Machine Model	520-50	
Lift Capacity at Full Height	lb (kg)	4400 (1996)
Lift Capacity at Full Reach	lb (kg)	1200 (544)
Maximum Lift Height	ft-in (mm)	16-5 (5000)
Reach at Maximum Lift Height	ft-in (mm)	2-0 (600)
Maximum Reach Forward	ft-in (mm)	9-7 (2921)
Placing Height	ft-in (mm)	15-1 (4600)

LOADER PERFORMANCE – Standard GP Bucket

Machine Model	520-50	
Bucket Rated Capacity	yd³ m³	0.9 (0.7)
Bucket Struck Capacity	yd³ m³	0.8 (0.61)
Breakout Force	lbf (kgf)	7054 (3200)
Dump Height (maximum)	ft-in (mm)	15-5 (4690)
Dump Angle at Maximum Height	degrees	35
Loadover Height (maximum)	ft-in (mm)	16-8 (5090)
Rollback Angle at Ground	degrees	45
Carriage Rotation Angle (total)	degrees	150
Payload (maximum)	lb (kg)	2777 (1260)
Bucket Width	ft-in (mm)	6-6 (1930)



CYCLE TIMES

	Seconds
Boom Raise	7.4
Boom Lower	5.3
Extend	5.7
Retract	3.2
Carriage Dump	2.3
Carriage Roll-back	3.2

ENGINE

Latest technology and advanced design provides low fuel consumption, reduced noise, high torque and power output, total reliability and minimal maintenance.

Two-stage, dry type air filter with primary and safety elements and pre cleaner.

Easily replaceable pre-finished dry liners, five bearing, heat treated crankshaft. Expansion controlled pistons.

Displacement	in ³ (l)	269 (4.4)
No of Cylinders		4
Bore Size	in (mm)	4.13 (105)
Stroke	in (mm)	5 (127)
Aspiration		Turbo
Power Rating @ 2200 rpm		
Gross SAE J1349	hp (kW)	83.8 (62.5)
Torque Rating @ 1400 rpm		
SAE J1349	lbf ft (Nm)	261 (354)

TRANSMISSION/AXLES

4 speed Synchro Shuttle– Travel Speed 18 mph (30 km/h)

Max-Trac torque proportioning axles.

Optional limited slip differential

Full time 4-wheel drive.

BRAKES/TIRES

Oil-immersed out-board front and rear axle

Separate electro/hydraulically operated oil-immersed disc type parking brake with transmission disconnect.

10.5/80-18 non ballasted tires.

Full time 4-wheel drive.

ATTACHMENTS

Standard Carriage	in	48
Side-tilt Carriage	in	48
Pallet Forks	in	42 or 48
Block Tines	in	48
Truss Boom	ft-in	12-6 Reach
General Purpose Bucket	yd ³	0.92
Light Material Bucket	yd ³	1.0
Scrap Grapple Bucket	yd ³	0.9

CAB FEATURES

ROPS/FOPS; Suspension seat; Front work lights; Shift lever transmission disconnect.

MISCELLANEOUS

Standard Auxiliary Hydraulics.

OPTIONS

Cab Enclosure with Heater/Defroster	Opt
Face Level Fan	Opt
Air Conditioner	Opt
Engine Block Heater	Opt
Rear Work Light Package	Opt
Front Limited Slip Axle	Opt



A GLOBAL COMMITMENT TO QUALITY

JCB's total commitment to its products and customers has helped it grow from a one-man business into one of the world's largest manufacturers of backhoe loaders, crawler excavators, wheeled excavators, telescopic handlers, wheeled loaders, dump trucks, rough terrain fork lifts, industrial fork lifts, mini/midi excavators, skid steer loaders and tractors.

By making constant and massive investments in the latest production technology, the JCB factories have become some of the most advanced in the world.

By leading the field in innovative research and design, extensive testing and stringent quality control, JCB machines have become renowned all over the world for performance, value and reliability.

And with an extensive dealer sales and service network in over 150 countries, we aim to deliver the best customer support in the industry.

Through setting the standards by which others are judged, JCB has become one of the world's most impressive success stories.



JCB Headquarters Savannah, 2000 Bamford Blvd, Savannah, GA 31322 Tel: (912) 447-2000 Fax: (912) 447-2299 www.jcb.com

JCB reserves the right to change design, materials and/or specifications without notice. Specifications are applicable to units sold in the United States and Canada. The JCB logo is a registered trademark of J.C. Bamford Excavators Ltd.